

ALARM CHECK VALVE

BRAND NAME	:	TYCO-CENTRAL
MODEL	:	AV-1-300
SIZE	:	2 1/2" DIA.
WORKING PRESSURE	:	300 PSI.
TESTED PRESSURE	:	600 PSI.
APPROVED	:	UL/FM APPROVED
FINISH	:	RED ENAMEL
CONNECTION	:	FLANGED x FLANGED

ACCESSORIES

TRIM	:	O - VERTICAL TRIM O - HORIZONTAL TRIM
RETARD CHAMBER	:	MODEL RC-1
WATER MOTOR ALARM	:	MODEL WMA-1

Model AV-1-300 Alarm Check Valve, 300 psi (20,7 bar) 2-1/2, 4, 6, & 8 Inch (DN65, DN100, DN150 & DN200) Vertical or Horizontal* Installation

General Description

The TYCO Model AV-1-300 Alarm Check Valves are divided seat ring, rubber-faced clapper, waterflow alarm check valves that are intended for use in wet pipe (automatic sprinkler) fire protection systems. They may be installed vertically or horizontally*, and they are designed to automatically actuate electric and/or hydraulic alarms when there is a steady flow of water into the system that is equivalent to the discharge rate of one or more sprinklers.

A separately ordered Model RC-1 Retard Chamber (TFP920) is required for installations subject to variable pressures. It is used to help prevent false alarms associated with pressure variations in public water supplies.

The AV-1-300 Alarm Check Valve Trim includes pressure gauges to monitor system pressure conditions, a by-pass check valve, a main drain valve, and an alarm test valve. The bypass check valve reduces the possibility of false alarms by permitting slow as well as small transient increases in water supply pressure to be passed through to the system without opening the waterway clapper.

NOTICE

The TYCO Model AV-1-300 Alarm Check Valves described herein must be installed and maintained in compliance with this document, as well as with the applicable standards of the National Fire Protection Association, in addition to the standards of any authorities having jurisdiction. Failure to do so may impair the integrity of these devices.

The owner is responsible for maintaining their fire protection system and devices in proper operating condition. The installing contractor or manufacturer should be contacted relative to any questions.



Nominal Valve Size	Groove x Groove	Flange x Groove	Flange x Flange
2-1/2 Inch (DN65)	22 lbs. (10,0 Kg)	28 lbs. (12,7 Kg)	N/A
4 Inch (DN100)	38 lbs. (17,2 Kg)	47 lbs. (21,3 Kg)	57 lbs. (25,9 Kg)
6 Inch (DN150)	58 lbs. (26,3 Kg)	70 lbs. (31,8 Kg)	84 lbs. (38,1 Kg)
8 Inch (DN200)	102 lbs. (46,3 Kg)	120 lbs. (54,4 Kg)	149 lbs. (67,6 Kg)

TABLE A
— AVAILABLE END CONNECTIONS —

* 4, 6, and 8 Inch (DN100, DN150, and DN200) Valve Sizes

VALVE PARTS			
NO.	DESCRIPTION	QTY.	REF.
1	Valve Body	1	NR
2	Handhole Cover . . .	1	NR
3	Handhole Cover Gasket	1	See (a)
4	Seat Ring	1	NR
5	Clapper	1	See (b)
6	Clapper Facing	1	See (a) or (b)
7	Clapper Washer	1	See (b)
8	Lock Nut, 2-1/2 Inch Valve . . .	1	See (b)
	Self-Locking Hex Cap Screw, 4, 6, & 8 Inch Valves	1	See (b)
9	Clapper Hinge Pin . . .	1	See (b)
10	Clapper Hinge Pin Bushing, 2-1/2 Inch Valve . . .	2	NR
	4, 6, & 8 Inch Valves	4	NR
11	Clapper Spring	1	See (b)

VALVE PARTS			
NO.	DESCRIPTION	QTY.	REF.
12	Handhole Cover Hex Bolt, 2-1/2 Inch Valve, 1/2-13 UNC-2A x 1-1/4" Long	4	CH
	4 Inch Valve, 1/2-13 UNC-2A x 1-3/4" Long	4	CH
	6 Inch Valve, 1/2-13 UNC-2A x 1-3/4" Long	6	CH
	8 Inch Valve, 3/4-10 UNC-2A x 2" Long	6	CH
13	Clapper Hinge Pin Square Head Pipe Plug, 3/8" NPT, 4, 6, & 8 Inch Valves only	1	CH

REPLACEMENT PARTS	
NO.	DESCRIPTION P/N
(a)	Repair Parts Kit, Includes 3 & 6
	2-1/2 Inch Valve 92-200-1-216
	4 Inch Valve 92-200-1-416
	6 Inch Valve 92-200-1-620
	8 Inch Valve 92-200-1-816
(b)	Clapper Assembly, Includes 5-9, 11
	2-1/2 Inch Valve 92-200-1-218
	Includes 5-11
	4 Inch Valve 92-200-1-423
	6 Inch Valve 92-200-1-623
	8 Inch Valve 92-200-1-823

- NOTES:**
1. F x F valve shown for reference; components for G x G and F x G valves are shared.
 2. NR: Not Replaceable
 3. CH: Common Hardware

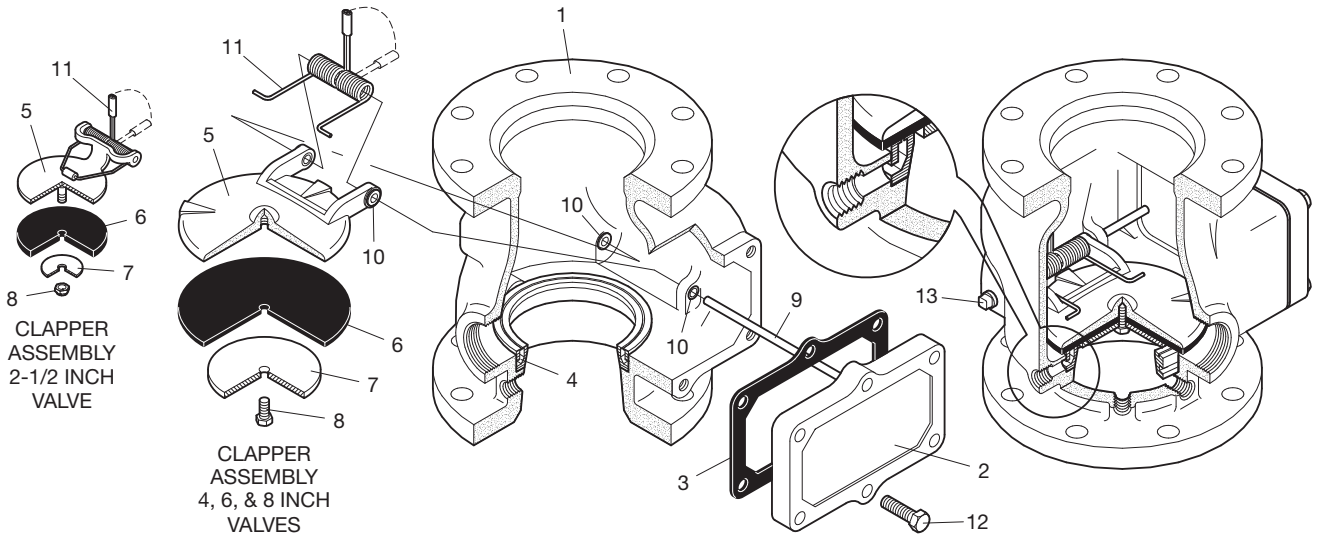

The 2-1/2 Inch (DN65) Valves with NPT threaded ports have a 1-1/4 inch main drain connection. The 2-1/2 Inch (DN65) Valves with ISO threaded ports have a DN40 main drain connection.

The 4, 6, and 8 Inch (DN100, DN150, and DN200) Valves with NPT threaded ports have a 2 inch main drain connection. The 4, 6, and 8 Inch (DN100, DN150, and DN200) Valves with ISO threaded ports have a DN50 inch main drain connection.

FIGURE 1
2-1/2, 4, 6 & 8 INCH (DN65, DN100, DN150 & DN200) MODEL AV-1-300 ALARM CHECK VALVE
— ASSEMBLY —

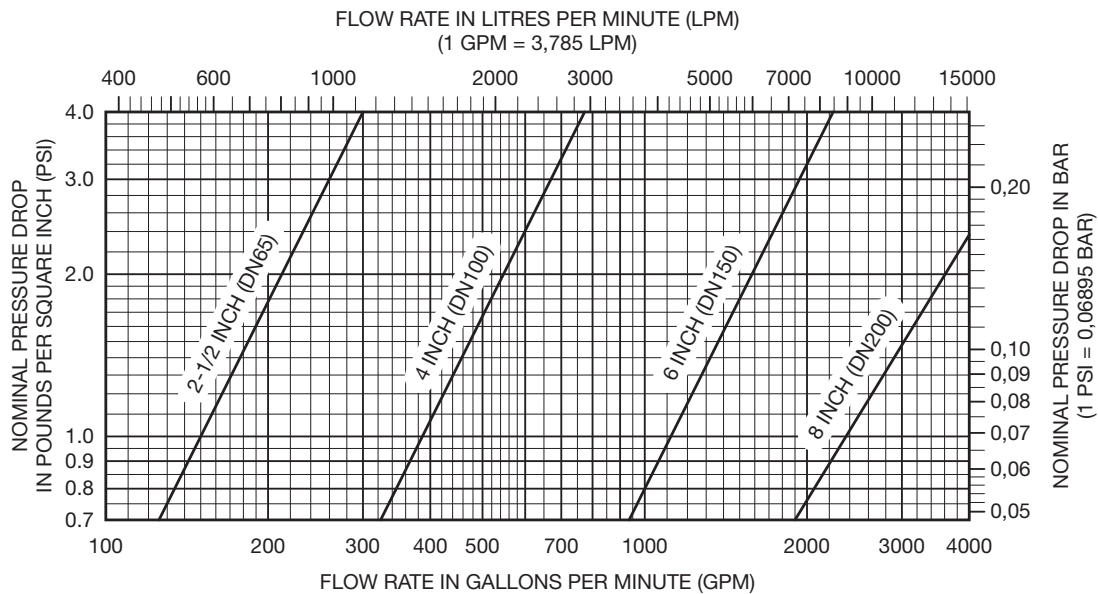

The approximate friction loss, based on the Hazen and Williams formula and expressed in equivalent length of pipe with C=120, is as follows

- 14 feet of 2-1/2 inch Sch. 40 pipe for the 2-1/2 inch AV-1-300 Valve calculated on a typical flow rate of 250 GPM.
- 23 feet of 4 inch Sch. 40 pipe for the 4 inch AV-1-300 Valve calculated on a typical flow rate of 600 GPM.
- 24 feet of 6 inch Sch. 40 pipe for the 6 inch AV-1-300 Valve calculated on a typical flow rate of 1500 GPM.
- 23 feet of 8 inch Sch. 30 pipe for the 8 inch AV-1-300 Valve calculated on a typical flow rate of 2500 GPM.

GRAPH A
2-1/2, 4, 6 & 8 INCH (DN65, DN100, DN150 & DN200) MODEL AV-1-300 ALARM CHECK VALVE
— NOMINAL PRESSURE LOSS VERSUS FLOW —

Nominal Valve Size	Flange Drilling Specification														
	Nominal Dimensions in Inches and (mm)														
	ANSI B16.1 (Class 125) ¹			ISO 2084 (PN10) ²			ISO 2084 (PN16) ³			JIS B 2210 (10K)			AS 2129 (Table E)		
Dim. A	Dim. B	Qty. N	Dim. A	Dim. B	Qty. N	Dim. A	Dim. B	Qty. N	Dim. A	Dim. B	Qty. N	Dim. A	Dim. B	Qty. N	
2-1/2 Inch (DN65)	5.50 (139,7)	0.75 (19,0)	4	USE ISO 2084 (PN16)			5.71 (145,0)	0.71 (18,0)	4	5.51 (140,0)	0.75 (19,0)	4	5.00 (127,0)	0.71 (18,0)	4
4 Inch (DN100)	7.50 (190,5)	0.75 (19,0)	8				7.09 (180,0)	0.71 (18,0)	8	6.89 (175,0)	0.75 (19,0)	8	7.00 (178,0)	0.71 (18,0)	8
6 Inch (DN150)	9.50 (241,3)	0.88 (22,2)	8				9.45 (240,0)	0.87 (22,0)	8	9.45 (240,0)	0.91 (23,0)	8	9.25 (235,0)	0.87 (22,0)	8
8 Inch (DN200)	11.75 (298,5)	0.88 (22,2)	8	11.61 (295,0)	0.87 (22,0)	8	11.61 (295,0)	0.87 (22,0)	12	11.42 (290,0)	0.91 (23,0)	12	11.50 (292,0)	0.87 (22,0)	8

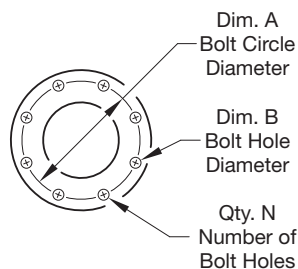

¹ Same drilling as for B16.5 (Class 150) and B16.42 (Class 250).
² Same drilling as for BS 4504 Section 3.2 (PN10) and DIN 2532 (PN10).
³ Same drilling as for BS 4504 Section 3.2 (PN16) and DIN 2532 (PN16).

TABLE B
— FLANGE DRILLING SPECIFICATIONS —

Technical Data

Approvals

UL and C-UL Listed,
FM Approved

Working Water Pressure Range

20 to 300 psi (1,4 to 20,7 bar)

Friction Loss

Refer to Graph A.

Physical Characteristics

The body is ductile iron, the hand-hole cover is ductile iron, and the seat ring is bronze. The clapper for the 2-1/2 inch (DN65) valve size is stainless steel. The clapper for the larger valve sizes is ductile iron. All valve sizes utilize an EPDM clapper facing.

Flanged connections are available drilled per ANSI, ISO, AS, and JIS specifications as detailed in Table A.

Threaded port connections for the AV-1-300 Valves are available NPT threaded or threaded per ISO 7/1 as detailed in the Ordering Procedure section. Valves with NPT threaded ports will readily accept the trim arrangements detailed in Figures 4 through 6.

Operation

When the fire protection system is initially pressurized, water flows into the system until the water supply and system pressure become equalized, and the torsion Spring closes the Waterway Clapper in the Alarm Check Valve. Once the pressures stabilize, the Alarm Check Valve is in service and the centrally located groove in the Seat Ring is sealed. Consequently, with the Alarm Check Valve set for service, there is no flow through the alarm port to the alarm devices (that is, water motor alarm and/or pressure alarm switch).

When there is a steady flow of water into the sprinkler system due to a sprinkler operation, the Waterway Clapper opens as shown in Figure 2. Water is then permitted to flow into the centrally located groove in the Seat Ring and out through the alarm port towards the Restriction Assembly (Figure 3). When the flow through the Inlet Restriction of the Restriction Assembly exceeds the flow through the Outlet Restriction, the Retard Chamber (where provided for systems with variable pressure), begins to fill.

Subsequently, the Water Motor alarm and/or the pressure alarm switch will be actuated. The alarms will continue

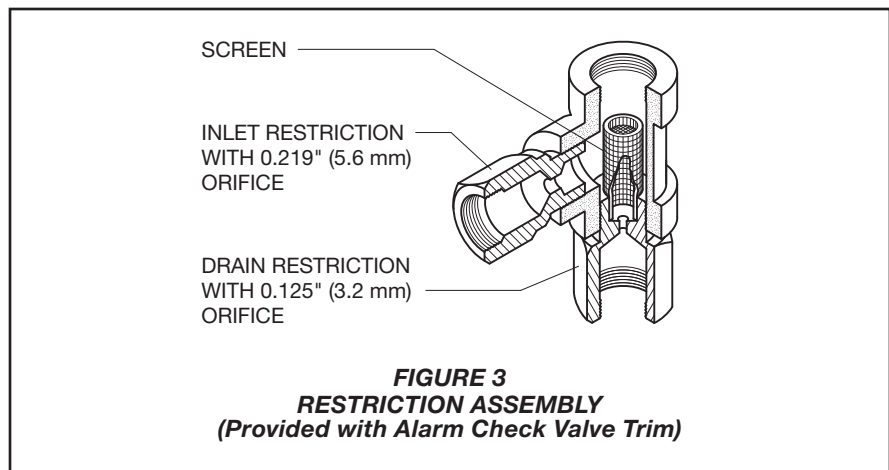
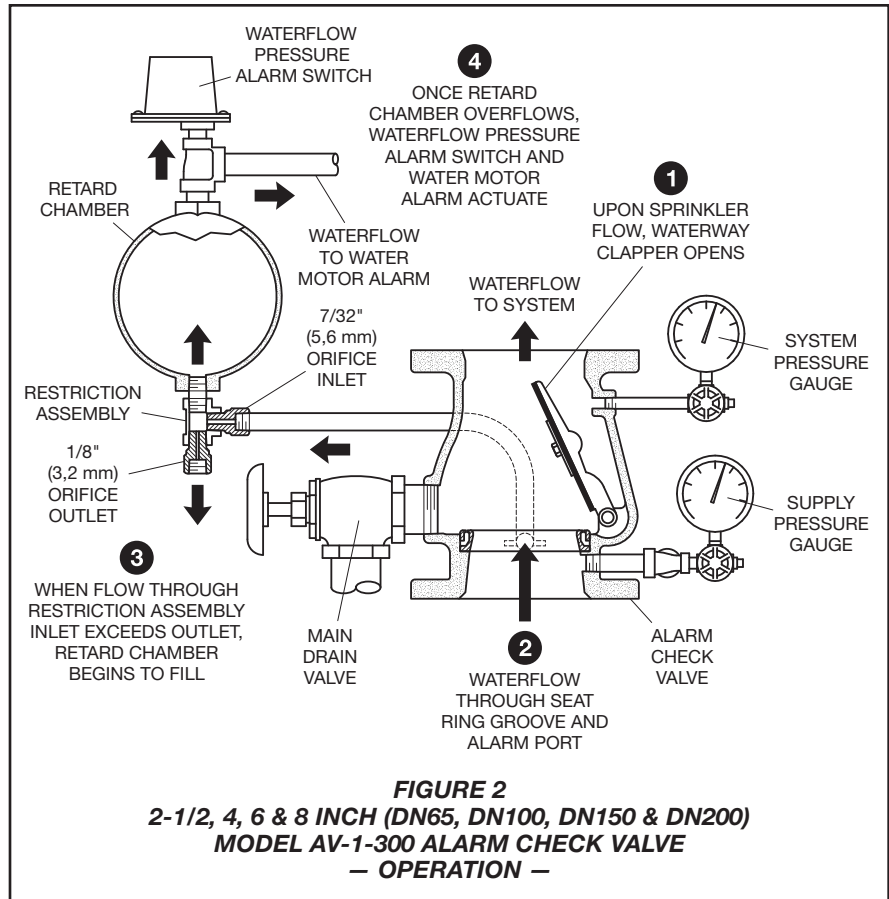

to be actuated as long as the Waterway Clapper remains open. Water in the alarm lines will automatically drain out through the 1/8 inch (3,2 mm) Drain Orifice in the Restriction Assembly (Figure 3) when the Waterway Clapper closes (due to a stop in the flow of water into the sprinkler system).

For variable pressure systems, slow as well as small transient increases in water supply pressure may continue to build up in the system (via the Bypass Check Valve) without opening the Waterway Clapper.

A transient surge in supply pressure that is sufficient only to open the Waterway Clapper momentarily will not cause a false alarm, and a portion of the increase in pressure will be trapped within the system, thus reducing the possibility of another opening. Any water in the alarm line is automatically drained, further reducing the possibility of a false alarm due to a successive transient surge in supply pressure.

Design Criteria

In planning installation of the TYCO Model AV-1-300 Alarm Check Valves, consideration must be given to the disposal of the large quantities of water that may be associated with draining the system or performing a flow test.

Valves installed in the vertical position must have the flow going up. Valves installed in the horizontal position must be positioned so that the drain connection points down.

The sprinkler system designer must be aware that the configuration of the piping network and its tendency to trap pockets of air (such as in the case of a peaked-roof gridded system) can affect the performance of the alarm system. Although a slight amount of trapped air is desirable to prevent significant pressure increases due to thermally induced expansion of the water, a large quantity of trapped air in a system may result in the possibility of an intermittent alarm.

The possibility of an intermittent alarm condition is a consequence of the fact that the flow out of the system through the test valve or a single sprinkler is very small relative to the flow that can be passed through the valve. This difference increases with valve size. If the system were free of trapped air, flow in would equal flow out and the Waterway Clapper would always stabilize at some open position (as needed to accommodate the required flow). With trapped air in the system, however, the Waterway Clapper first opens wider since the system initially demands greater flow until the air pockets are compressed (back to nearly the supply pressure), and then it will tend to return closer to the Seat Ring. If the volume of the air pockets is excessive, flow into the system can be momentarily reduced to nearly zero (once the air pockets are compressed) and the Waterway Clapper may close, causing flow to the alarms to be shutoff.

After the Waterway Clapper has closed, sufficient water must flow out of the system before the Waterway Clapper will again open. A repetition of the above described condition is termed an intermittent alarm.

Using a vent (which can also serve as an end-of-line Inspector's Test Connection) piped from the top of a cross main or end of a branch line at the point most remote from the alarm valve, and filling the system slowly in accordance with the steps described in the Setting Procedure section, can prevent an excessive amount of air from being trapped.

Installation

NOTICE

Proper operation of the TYCO Model AV-1-300 Alarm Check Valves depends upon the trim described in this data sheet installed in accordance with the following instructions. Failure to follow the appropriate trim installation instructions may prevent the device from functioning properly as well as void listings/approvals and the manufacturer's warranties.

The Alarm Check Valves must be installed in readily visible and accessible locations.

It is recommended that provision be made for viewing the alarm line drain water by locating the main drain outlet in a readily visible area.

Wet pipe fire protection systems must be maintained at a minimum temperature of 40°F/4°C.

1. Trim the Alarm Check Valve in accordance with Figure 4, 5, or 6, as applicable. Apply pipe-thread sealant sparingly to male threads only.
2. The Alarm Vent Trim illustrated in Figure 8 must be installed if a water motor alarm is not to be used.
3. Plug unused alarm connections.
4. Suitable provision must be made for disposal of alarm line and system drainage water. Drainage water must be directed so that it will not cause damage or result in dangerous conditions.
5. The alarm line drain must be arranged so that there will be no danger of freezing.

6. The check valve in the externally mounted bypass around the Waterway Clapper must be installed with its arrow pointed up, and the drain check valve must be installed with its arrow pointing towards the drain.
7. It is recommended that a vent connection (which may also be used as an end-of-line Inspector's Test Connection), be piped from a cross main or branch line at the point most remote from the alarm valve. The vent line should be connected to the top of a cross main or to the end of a branch line and be located at the highest level of a multi-level installation.

The vent connection can be used to bleed-off excessive air from the system, and therefore, minimize the possibility of a false alarm due to a transient surge in supply pressure. The contraction/expansion associated with an excessive amount of trapped air could also cause the Waterway Clapper to cycle open and shut during an inspector's test or during a discharge by a single sprinkler.

Model RC-1 Retard Chamber For Variable Pressure Wet Pipe Sprinkler Systems 300 psi (20,7 bar)

General Description

The Model RC-1 Retard Chamber is required in installations that will be subject to pressure variations, as are generally associated with public water supplies in order to help prevent false alarms. The RC-1 is specifically intended for use as a separately ordered item for the Model AV-1-300 (TFP910) and AV-1-175 (TFP912) Alarm Check Valves. It can, however, also be used as a separately ordered item for changing out older style Retard Chambers used with the Central Model F/G, Gem Model A, or Star Model E/F Alarm Check Valves.

The Model RC-1 Retarding Chamber is a redesignation for the Gem Model F211 for use with Gem Model F20/F200/F2001 Alarm Check Valves, as well as the Star Model S310 for use with Star Model S30/S300/S3001 Alarm Check Valves.

WARNING

The Model RC-1 Retard Chamber described herein must be installed and maintained in compliance with this document, as well as with the applicable standards of the National Fire Protection Association, in addition to the standards of any other authorities having jurisdiction. Failure to do so may impair the integrity of this device.

The owner is responsible for maintaining their fire protection system and devices in proper operating condition. The installing contractor or sprinkler manufacturer should be contacted relative to any questions.

Technical Data

Approvals

UL and ULC Listed, as well as FM, LPCB, and VdS Approved for use with the following Alarm Check Valves:

Model AV-1-175
Gem Model F20/F200/F2001
Gem Model A
Star Model S30/S300/S3001

UL and ULC Listed, as well as FM Approved for use with the Model AV-1-300 Alarm Check Valves.

Working Water Pressure
300 psi (20,7 bar)

Construction

The Model RC-1 Retard Chamber shown in Figure 1 is cast iron, and a 3/4" x 1/2" x 3/4" Tee is provided at the outlet (top) for connection of a pressure alarm switch and/or water motor alarm. The Restriction Assembly shown in Figure 2 is comprised of brass restrictions assembled to a cast iron or malleable iron threaded tee fitting. The screen is stainless steel.

Operation

When there is a steady flow of water into the sprinkler system due to a sprinkler operation, the Clapper in the Alarm Check Valve opens as shown in Figure 3. Water is then permitted to flow into the centrally located groove in the Seat Ring and out through the alarm port towards the Restriction Assembly (Figure 2). When the flow through the inlet restriction of the Restriction Assembly exceeds the flow out through the outlet restriction, the Retard Chamber begins to fill. Subsequently, the water motor alarm and/or the pressure alarm switch will be actuated. The alarms will continue to be actuated as long as the Clapper in the Alarm Check Valve remains open. Water in the alarm lines will auto-



matically drain out through the 1/8" (3,2 mm) drain orifice in the Restriction Assembly (Figure 2) when the Alarm Valve Clapper closes (due to a discontinuation in the flow of water into the sprinkler system).

In the case of variable pressure systems, a transient surge in supply pressure that is sufficient to only momentarily open the Alarm Valve Clapper will not cause a false alarm, since the volume of the Retard Chamber is sufficiently large enough that it will not have filled to operate the connected alarm devices. Any water in the alarm line is then automatically drained, further reducing the possibility of a false alarm due to a successive transient surge in supply pressure.

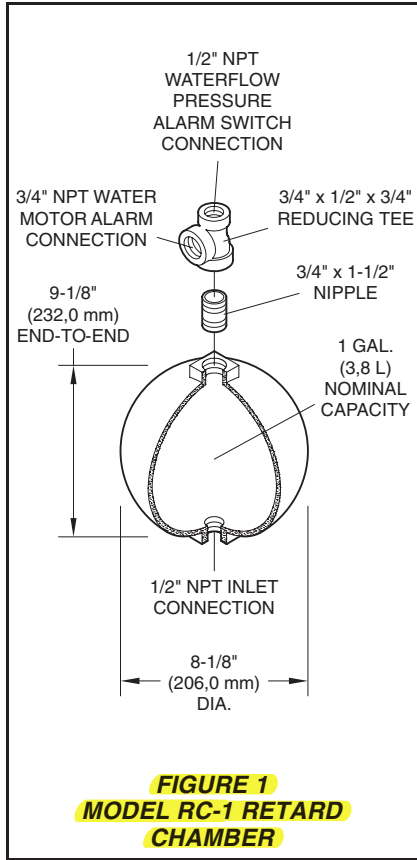

FIGURE 1
MODEL RC-1 RETARD CHAMBER

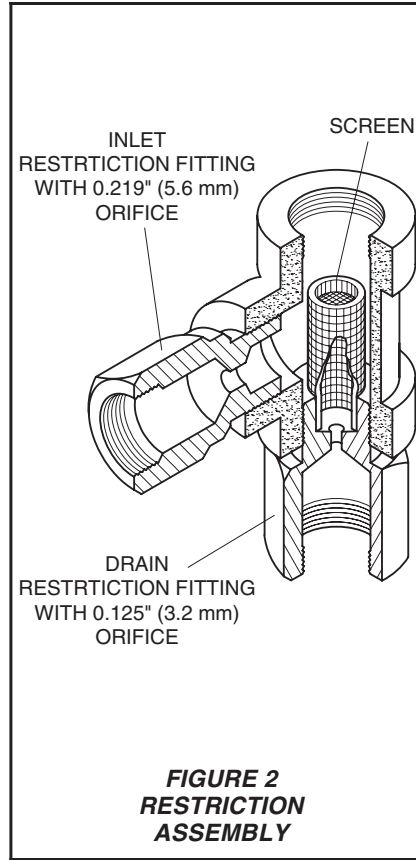

FIGURE 2
RESTRICTION ASSEMBLY

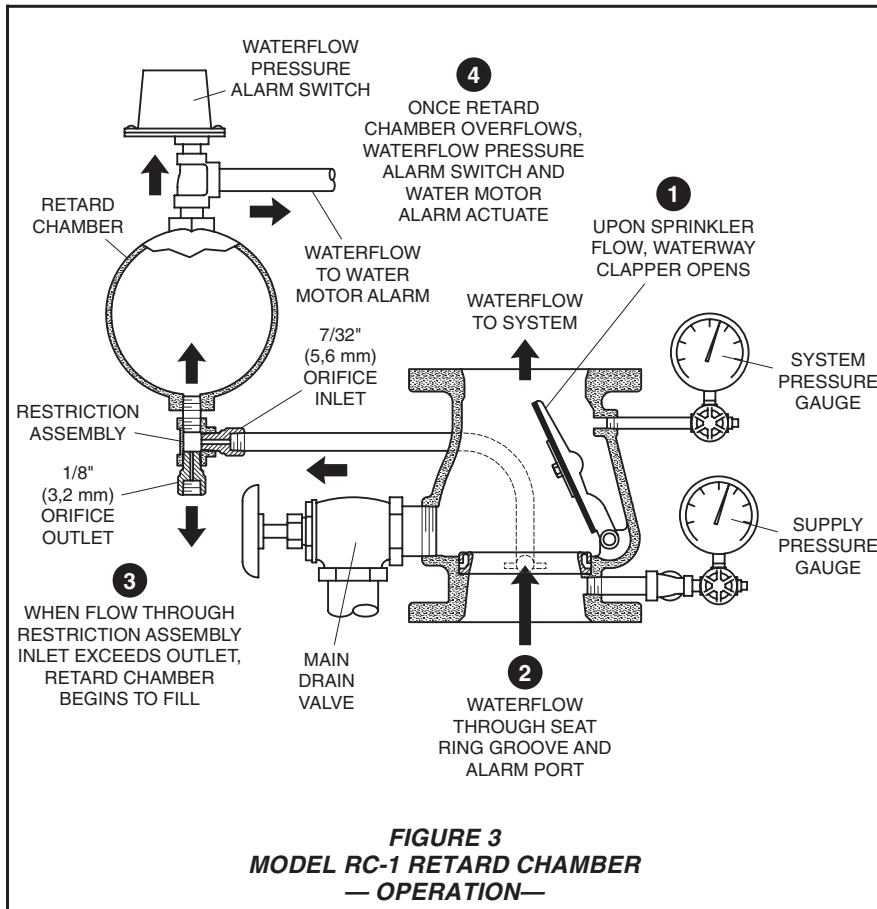

FIGURE 3
MODEL RC-1 RETARD CHAMBER
— OPERATION —

Installation

The Model RC-1 Retard Chamber must be installed in accordance with the specific instructions provided with the Tyco Fire Products Model AV-1-300 (TFP910) or Model AV-1-175 (TFP912) Alarm Check Valves. The standard trim for these Alarm Check Valves includes all of the necessary components including the Restriction Assembly shown in Figure 2.

In the case of retrofitting Central Model F/G Alarm Check Valves refer to Figure 4; In the case of retrofitting Gem Model A Alarm Check Valves refer to Figure 5; and, in the case of retrofitting Star Model E/F Alarm Check Valves refer to Figures 6 and 7.

NOTE

When retrofitting per Figures 4, 5, 6, or 7, the Restriction Assembly, Y-Strainer, and associated pipe nipples and fittings must be ordered separately to complete the installation.

Apply pipe thread sealant sparingly to male threads only.

Care and Maintenance

The owner is responsible for the inspection, testing, and maintenance of their fire protection system and devices in compliance with this document, as well as with the applicable standards of the National Fire Protection Association (e.g., NFPA 25), in addition to the standards of any authority having jurisdiction. The installing contractor or product manufacturer should be contacted relative to any questions.

It is recommended that automatic sprinkler systems be inspected, tested, and maintained by a qualified Inspection Service.

Specific consideration must be given to cleaning the Screen within the Restriction Assembly, as well as the Y-Strainer. More frequent cleaning than that required by NFPA 25 may be necessary as determined after the first inspection and is a function of the water quality with respect to water borne debris.

NOTES

Before closing a fire protection system control valve for inspection or maintenance work on the fire protection system that it controls, permission to shut down the affected fire protection system must first be obtained from the proper authorities, and all personnel

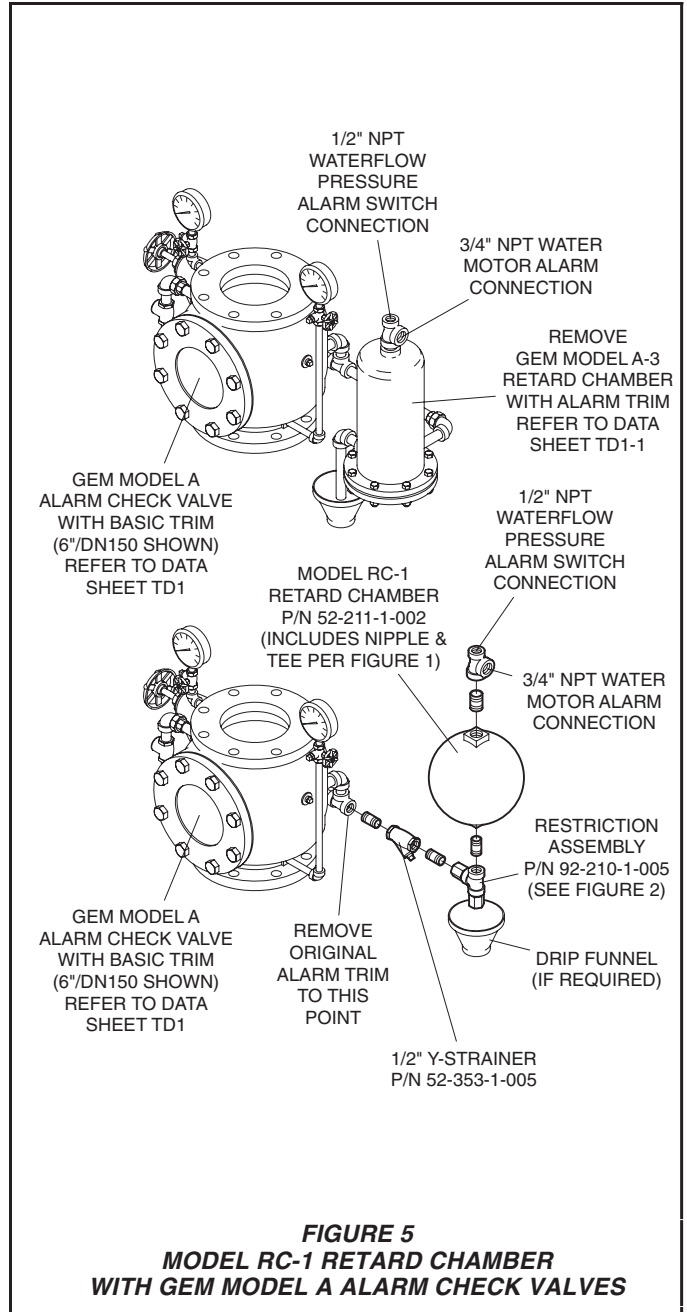
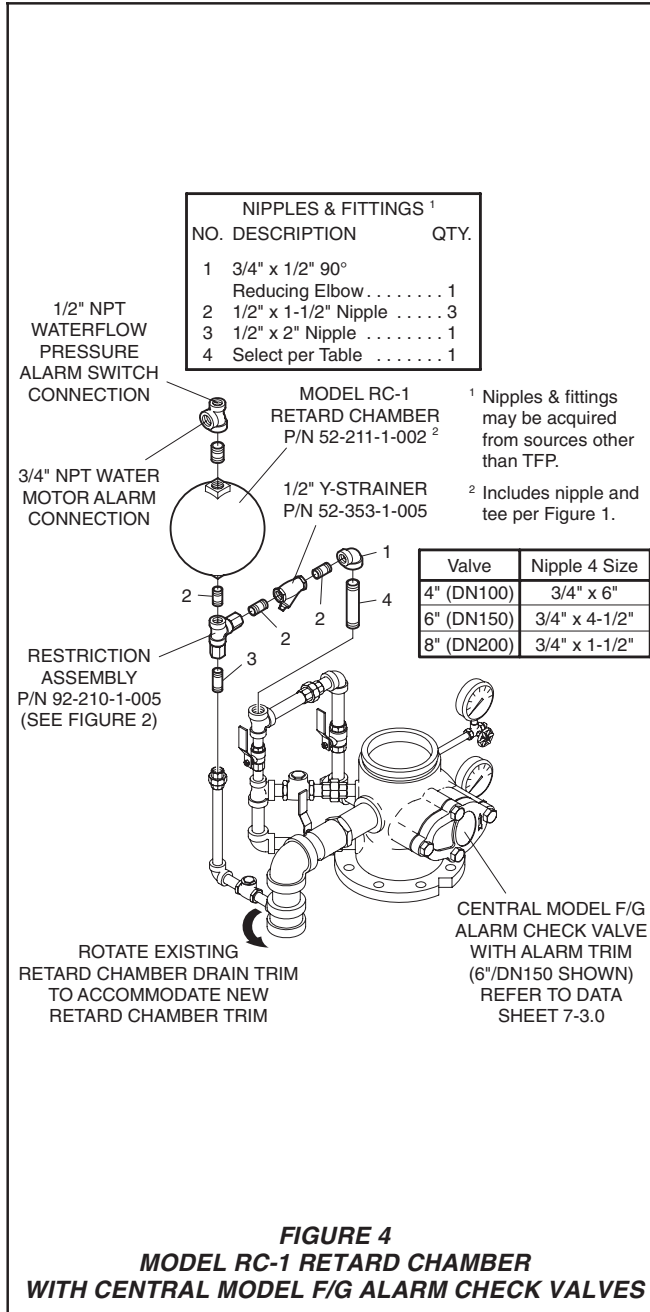

who may be affected by this action must be notified.

After placing a fire protection system in service, notify the proper authorities and advise those responsible for monitoring proprietary and/or central station alarms.

Limited Warranty

Products manufactured by Tyco Fire Products are warranted solely to the original Buyer for ten (10) years against defects in material and workmanship when paid for and properly installed and maintained under normal use and service. This warranty will expire ten (10) years from date of shipment by Tyco Fire Products. No warranty is given for products or components manufactured by companies not affiliated by ownership with Tyco Fire Products or for products and

components which have been subject to misuse, improper installation, corrosion, or which have not been installed, maintained, modified or repaired in accordance with applicable Standards of the National Fire Protection Association, and/or the standards of any other Authorities Having Jurisdiction. Materials found by Tyco Fire Products to be defective shall be either repaired or replaced, at Tyco Fire Products' sole option. Tyco Fire Products neither assumes, nor authorizes any person to assume for it, any other obligation in connection with the sale of products or parts of products. Tyco Fire Products shall not be responsible for sprinkler

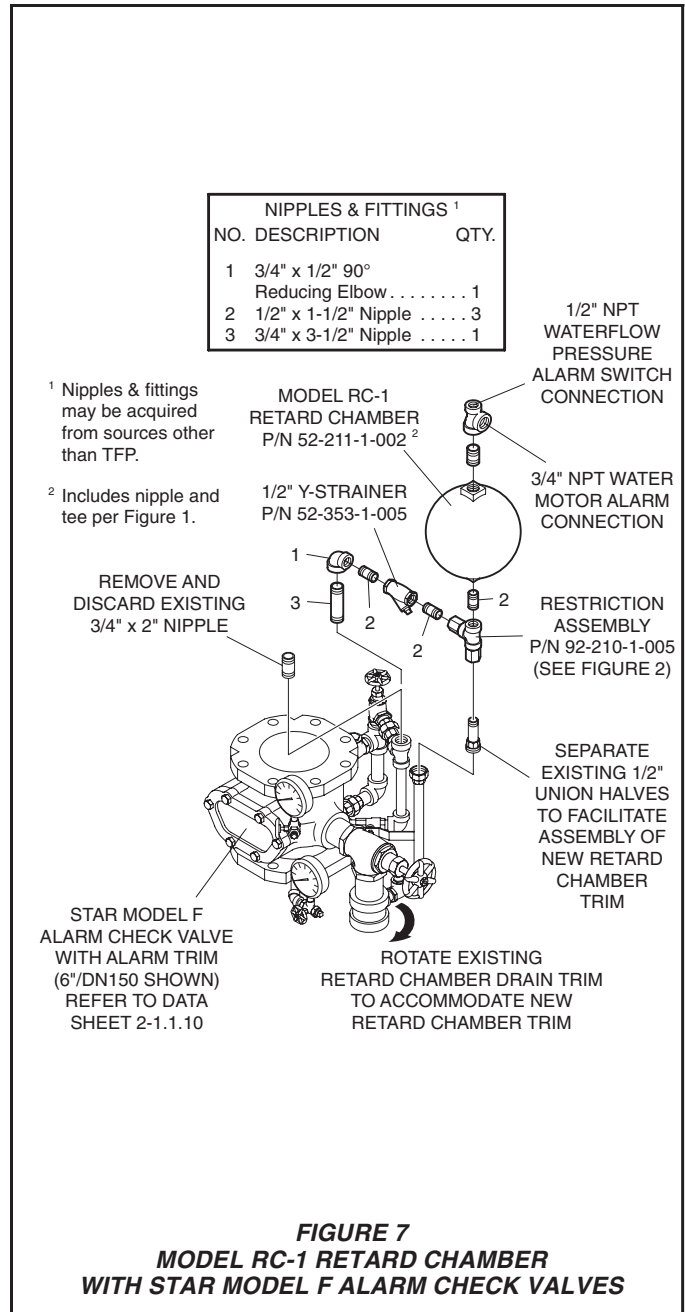
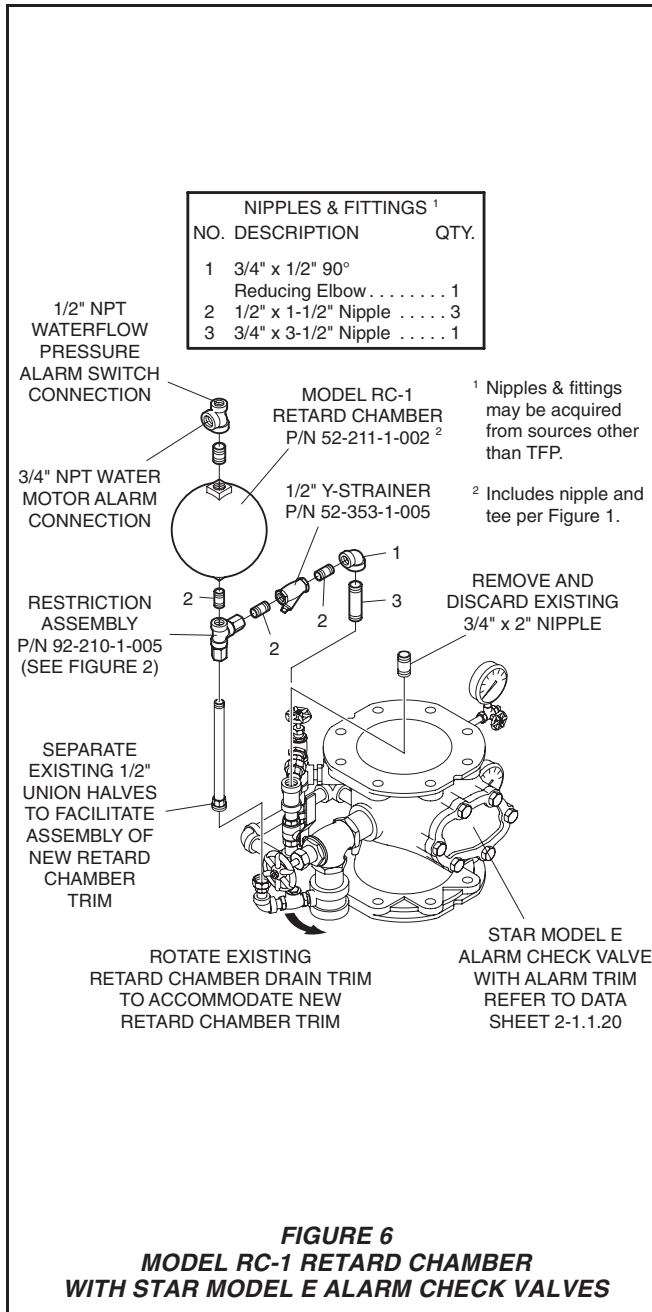

system design errors or inaccurate or incomplete information supplied by Buyer or Buyer's representatives.

IN NO EVENT SHALL TYCO FIRE PRODUCTS BE LIABLE, IN CONTRACT, TORT, STRICT LIABILITY OR UNDER ANY OTHER LEGAL THEORY, FOR INCIDENTAL, INDIRECT, SPECIAL OR CONSEQUENTIAL DAMAGES, INCLUDING BUT NOT LIMITED TO LABOR CHARGES, REGARDLESS OF WHETHER TYCO FIRE PRODUCTS WAS INFORMED ABOUT THE POSSIBILITY OF SUCH DAMAGES, AND IN NO EVENT SHALL TYCO FIRE PRODUCTS' LI-

ABILITY EXCEED AN AMOUNT EQUAL TO THE SALES PRICE.

THE FOREGOING WARRANTY IS MADE IN LIEU OF ANY AND ALL OTHER WARRANTIES EXPRESS OR IMPLIED, INCLUDING WARRANTIES OF MERCHANTABILITY AND FITNESS FOR A PARTICULAR PURPOSE.

Ordering Information

Orders for the RC-1 and additional components, as applicable, must in-

clude the description and Part Number (P/N).

RC-1:
Specify: Model RC-1 Retard Chamber w/galvanized steel fittings, P/N 52-211-2-002.

NOTE

When retrofitting per Figures 4, 5, 6, or 7, the Restriction Assembly, Y-Strainer, and associated pipe nipples and fittings must be ordered separately to complete the installation.

Model WMA-1 Water Motor Alarm Hydraulically Operated Mechanical Sprinkler Alarm

General Description

The Model WMA-1 Water Motor Alarm is a hydraulically operated outdoor alarm designed for use with fire protection system waterflow detection valves. It is lightweight yet rugged, and it can be used in conjunction with alarm check, dry pipe, deluge, and preaction valves to sound a local alarm.

The Water Motor Alarm is suitable for mounting to any type of rigid wall and can accommodate a wall thickness range of 2 to 18 inches (50 to 450 mm). It is provided with a listed and approved Model WM-1 Y-Strainer for use in the alarm line.

The WMA-1 utilizes a lightweight, impeller design which can produce a very high sound pressure level. The Gong, Gong Mount, and Water Motor Housing are fabricated from corrosion resistant aluminum alloys. The polymer drive bearings do not require lubrication, and the Gong is closely fitted to the Gong Mount to eliminate the need for a separate cover.

The Model WMA-1 Water Motor Alarm is a redesignation for the Central Model F-2, Gem Model F630, and Star Model S450.

WARNING

The Model WMA-1 Water Motor Alarm described herein must be installed and maintained in compliance with this document, as well as with the applicable standards of the National Fire Protection Association, in addition to the standards of any other authorities having jurisdiction. Failure to do so may impair the performance of this device.

The owner is responsible for maintaining their fire protection system and devices in proper operating condition. The installing contractor or sprinkler manufacturer should be contacted with any questions.

Technical Data

Approvals
UL and ULC Listed.
FM, LPCB, and VdS Approved.

Gong Finish
Red or Aluminum

Working Water Pressure Range
7 to 300 psi (0,5 to 20,7 bar)

Nozzle K-Factor
0.7 GPM/psi^{1/2} (10,1 LPM/bar^{1/2})

Y-Strainer
3/4 inch, cast iron, 20 mesh screen

Trim Components
Galvanized steel nipples and cast iron fittings.

Design Data

The Model WMA-1 Water Motor Alarm must be used in accordance with the following design criteria:

Item 1. The Y-Strainer is to be located at the "alarm outlet" of the waterflow detection valve trim.

Item 2. The Water Motor Alarm must only be mounted to a rigid wall surface, which will not permit the Striker/Gong Mount to loosen and fall out of alignment.

Item 3. In order to obtain the highest possible sound level, the Water Motor Alarm should be located as close as possible to the waterflow detecting valve. (Refer to NFPA 13 for guidance.)

Item 4. The alarm line piping from the alarm outlet of the waterflow detection valve trim to the Water Motor Alarm must be 3/4 inch size throughout and it must be galvanized steel, brass, or other suitable corrosion resistant material.

Item 5. The alarm line piping must be



positioned such that it can be drained back to the water flow detection valve trim.

Item 6. The Clean-Out Sump Plug is to be located vertically below the Inlet to the Water Motor.

Item 7. Piping from the Water Motor Drain must be a minimum of 1 inch in size throughout and directed to an open drain, in order to ensure proper drainage for obtaining the maximum sound pressure level.

NOTE

The Water Motor Alarm Drain may be connected to the main drain of a water flow detection valve if a non-spring loaded swing type check valve is installed in a horizontal portion of the water motor alarm drain piping (before its connection to the main drain).

Item 8. In order to minimize any wall staining that can be created by drain water, it is recommended that the drain piping from the Water Motor be galvanized steel, brass, or other suitable corrosion resistant material.

Item 9. Drain water must be directed such that there will be no accidental damage to property or danger to persons when the alarm is operating or thereafter.

Item 10. The alarm line drain (at the

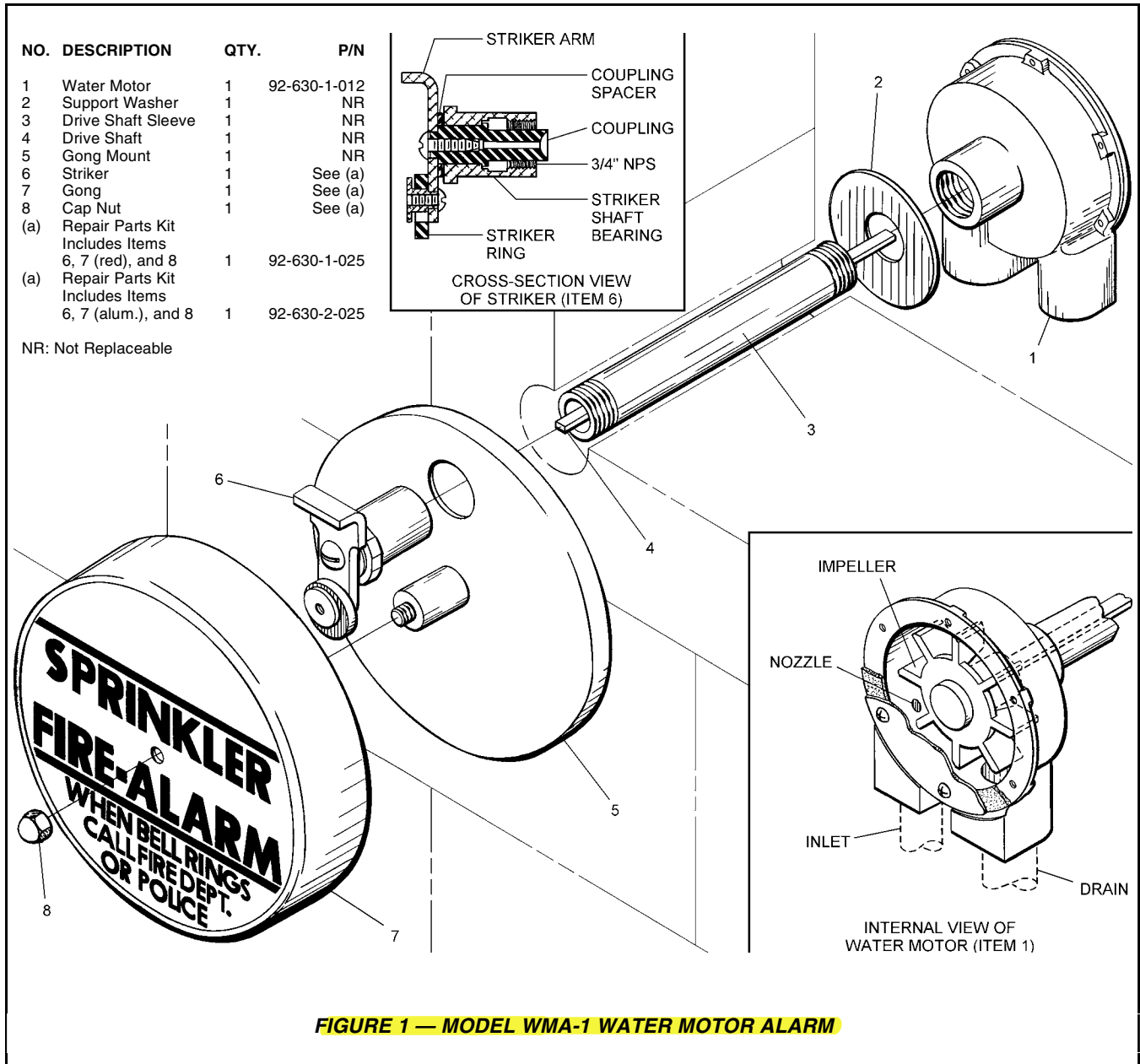

waterflow detection valve) must be maintained at a minimum temperature of 40°F/4°C.

Item 11. A single Water Motor Alarm may be connected to the alarm lines from a maximum of three separate fire protection systems. However, when two or three alarm lines are interconnected, each alarm line must be provided with a 3/4 inch (P/N 52-271-1-001) Model WM-1 Y-Strainer and a 3/4 inch (P/N 52-403-1-005) Check Valve with 3/32 inch orifice. The strainers must be located at the "alarm outlet" in the trim of each of the waterflow detection valves. The check valves must be located between each strainer and the interconnection with the alarm line from another system.

Operation

Upon operation of the alarm check, dry pipe, deluge, or preaction valve to which the Model WMA-1 Water Motor Alarm is connected, water will flow to the Water Motor and through the Inlet Nozzle. As water flows through the Inlet Nozzle, a high velocity jet is formed which impinges on the Impeller, causing the Impeller and the Striker to rotate. With each rotation, the free swinging Striker Ring hits the Gong and sounds the alarm. The spent water is then drained through the 1 inch outlet.

The alarm will sound as long as water is flowing into the system and flowing to the Water Motor Alarm. Water in the

alarm line will automatically drain back through the orifice which is also provided in the trim of the waterflow detection valve.

The Water Motor Alarm does not have to be reset after an operation. However, if the alarm was silenced during operation by closing of an alarm control valve, the alarm control valve must be reopened after the fire protection system is restored to service.

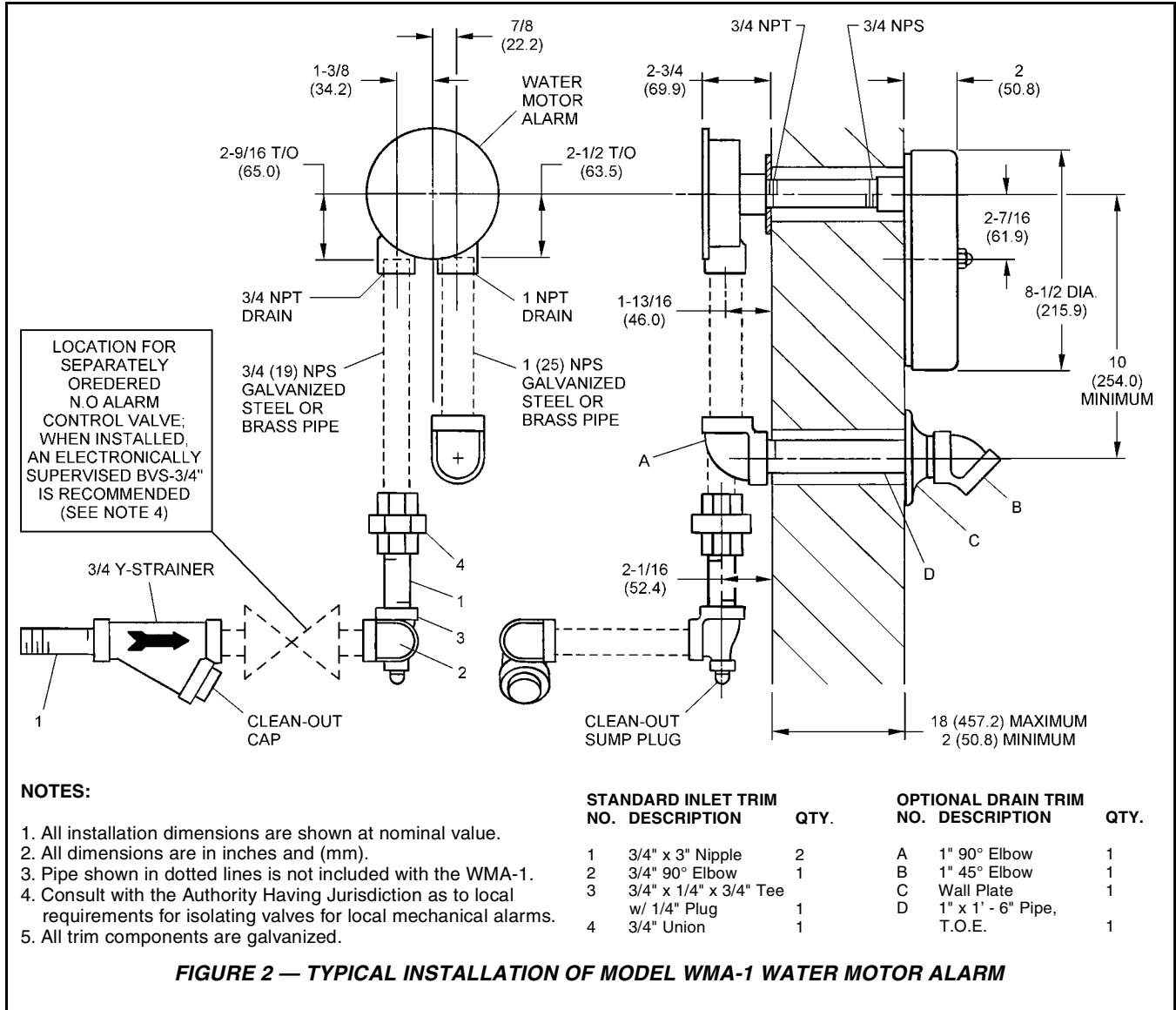

Installation

The Model WMA-1 Water Motor Alarm must be installed in accordance with the following instructions:

Step 1. Mark the through-wall locations for the centerlines of the Sleeve and Drain Outlet. The Drain Outlet must be located at least 10 inches (250 mm) below the Sleeve per Figure 2.

Step 2. Make 1-1/2 inch (38 mm) diameter holes straight through the wall at both locations.

Step 3. Cut the non-threaded end of the Sleeve to a length equal to that of the wall thickness plus 0 to 1/8 inch (0 to 3 mm). Thread the cut end to 3/4 inch NPT per ANSI B1.20.1.

Step 4. Install the alarm line piping up to and including the union half, Item 4 - Fig. 2.

NOTE

Use thread sealant sparingly on male threads only.

Step 5. Prior to initiating installation of the Water Motor Alarm, mount the Drain Trim (less the Wall Plate and 45° Elbow), as well as the balance of alarm line piping (including other union half) to the Water Motor.

Step 6. Tighten the NPT threaded end of the Sleeve into the Body hand tight plus 1/8 turn.

Step 7. Slip the Support Washer over the Sleeve and place the assembly in position against the wall.

Step 8. Tighten the 3/4 inch Union. Install the Wall Plate and tighten the 45° Elbow.

NOTE

Apply pressure against the outside edge of the Water Motor Body and

verify that the Body and Support Washer sit square against the wall. If not, adjust the alarm line and/or drain piping to suit.

Step 9. From the outside wall, insert the Drive Shaft through the Sleeve and fully insert it into the Impeller. (When fully inserted, the Shaft should protrude beyond the face of the wall by approximately 20" minus 2" minus wall thickness.)

Mark the Drive Shaft at a point of approximately 1/8 to 1/4 inch inside the face of the wall; remove the Shaft; cut the Shaft where previously marked; file off burrs from the cut end of the Drive Shaft; and, re-insert the Drive Shaft through the Sleeve and fully insert it into the Impeller.

Step 10. Hold the Gong Mount in position against the wall, engage the Coupling with the Drive Shaft and then carefully thread the Striker Shaft Bear-

ing onto the Sleeve. Securely tighten the Striker Shaft Bearing using a pair of channel locks on the 1-1/2 inch (38 mm) hex end.

Step 11. Spin the Striker by hand and verify that it spins freely (without any sign of binding). If not, make the necessary adjustments.

Step 12. Install the gong and securely tighten the Cap Nut. The identification sign lettering must be orientated horizontally,

Step 13. Test the Water Motor Alarm by opening the alarm test valve in the trim of the water flow detection valve. The alarm must be clear and steady. If not, make the necessary adjustments.

NOTE

Testing of the Water Motor Alarm may result in operation of other associated alarms. Consequently, notification must be given to the owner and the fire department, central control station, or other signal station to which the alarms are connected.

Care and Maintenance

The following procedures and inspections should be performed as indicated, in addition to any specific requirements of the NFPA, and any impairment must be immediately corrected.

The owner is responsible for the inspection, testing, and maintenance of their fire protection system and devices in compliance with this document, as well as with the applicable standards of the National Fire Protection Association (e.g., NFPA 25), in addition to the standards of any authority having jurisdiction. The installing contractor or product manufacturer should be contacted relative to any questions.

It is recommended that automatic sprinkler systems be inspected, tested, and maintained by a qualified Inspection Service in accordance with local requirements and/or national codes.

NOTES

Before closing a fire protection system main control valve for maintenance work on the fire protection system that it controls, permission to shut down the affected fire protection systems must first be obtained from the proper authorities and all personnel who may be affected by this decision must be notified.

Testing of the Water Motor Alarm may result in operation of other associated alarms. Consequently, notification

must be given to the owner and the fire department, central control station, or other signal station to which the alarms are connected.

If the alarm was silenced during operation, the alarm control valve must be reopened immediately after the fire protection system is restored to service.

The Model WMA-1 Water Motor Alarm must be maintained and serviced in accordance with the following instructions:

Step 1. The Model WMA-1 Water Motor Alarm does not require any regularly scheduled maintenance. Rotating parts do not require lubrication. It is recommended, however, that fire alarms be periodically operated, i.e., inspected, to verify that they generate a clear and steady sound. Any impairment must be immediately corrected.

Step 2. The inspection should be made quarterly or more frequently, as may be necessary in the case of locations subject to vandalism. The Y-Strainer and Sump are to be cleaned out after each operation of the Water Motor Alarm and after the alarm line piping has been drained.

Limited Warranty

Products manufactured by Tyco Fire Products are warranted solely to the original Buyer for ten (10) years against defects in material and workmanship when paid for and properly installed and maintained under normal use and service. This warranty will expire ten (10) years from date of shipment by Tyco Fire Products. No warranty is given for products or components manufactured by companies not affiliated by ownership with Tyco Fire Products or for products and components which have been subject to misuse, improper installation, corrosion, or which have not been installed, maintained, modified or repaired in accordance with applicable Standards of the National Fire Protection Association, and/or the standards of any other Authorities Having Jurisdiction. Materials found by Tyco Fire Products to be defective shall be either repaired or replaced, at Tyco Fire Products' sole option. Tyco Fire Products neither assumes, nor authorizes any person to assume for it, any other obligation in connection with the sale of products or parts of products. Tyco Fire Products shall not be responsible for sprinkler system design errors or inaccurate or incomplete information supplied by Buyer or Buyer's representatives.

IN NO EVENT SHALL TYCO FIRE PRODUCTS BE LIABLE, IN CONTRACT, TORT, STRICT LIABILITY OR UNDER ANY OTHER LEGAL THEORY, FOR INCIDENTAL, INDIRECT, SPECIAL OR CONSEQUENTIAL DAMAGES, INCLUDING BUT NOT LIMITED TO LABOR CHARGES, REGARDLESS OF WHETHER TYCO FIRE PRODUCTS WAS INFORMED ABOUT THE POSSIBILITY OF SUCH DAMAGES, AND IN NO EVENT SHALL TYCO FIRE PRODUCTS' LIABILITY EXCEED AN AMOUNT EQUAL TO THE SALES PRICE.

THE FOREGOING WARRANTY IS MADE IN LIEU OF ANY AND ALL OTHER WARRANTIES EXPRESS OR IMPLIED, INCLUDING WARRANTIES OF MERCHANTABILITY AND FITNESS FOR A PARTICULAR PURPOSE.

Ordering Information

Orders for the WMA-1, Optional Drain Trim, and replacement parts must include the description and Part Number (P/N).

The Complete Model WMA-1 Alarm Assembly includes the Model WMA-1 Water Motor Alarm, Model WM-1 Strainer, and Standard Inlet Trim.

WMA-1 Alarm Assemblies:

Specify: Model WMA-1 Alarm Assembly with Red Finish Gong, P/N 52-630-1-001.

or

Specify: Model WMA-1 Alarm Assembly with Aluminum Finish Gong, P/N 52-630-2-001

Optional Drain Trim:

Specify: Optional Drain Trim for Model WMA-1 Water Motor Alarm, P/N 52-630-2-002.

Separately Ordered Alarm Control Valve:

Specify: UL/FM 3/4 Inch Ball Valve, P/N 92-300-1-006.

Separately Ordered Parts for Multiple Systems:

Specify: Model WM-1 Y-Strainer, P/N 52-271-1-001. (1 required for two system, 2 required for 3 systems.)

Specify: 3/4 Inch Check valve with 3/32 Inch Orifice, P/N 52-403-1-005 (2 required for two system, 3 required for 3 systems.)

Replacement Parts for Water Motor Alarm:

(Specify description) for use with Model WMA-1 Water Motor Alarm, P/N (see Figure 1).

Waterflow Alarm Valves

Waterflow alarm valves (alarm check valves) are installed in either vertical or horizontal positions in wetpipe sprinkler systems to sound a fire alarm gong when a flow of water from the system equals or exceeds that of a single sprinkler. They are designed for use with hydraulic or electric gongs or both.

There are two designs, the differential type and the pilot valve type. The differential type has a rubber-faced clapper with an annular groove in the seat; the pilot valve type has a metal-faced clapper with a pilot valve attached to the clapper arm.

A retard chamber, which minimizes false alarms due to surges and fluctuations in water supply pressure, may be supplied with the alarm valve. If a retard chamber is supplied, *only the listed chamber for a specific manufacturer and valve model shall be used*. Alarm valves are FM Approved with specific trim, and no substitutes or omissions in part or in full are allowed.

Alarms are tested by flowing water through the system test pipe. Pilot valves may be field-adjusted to assure alarm reliability. Unless otherwise noted in the listing, these valves have 175 psi (1205 kPa) rated working pressure.

Model AV-1

Product Specification

Model No	Valve Size		Rated Working Pressure		End Connection	Remarks
	in	(mm)	psi	(kPa)		
AV-1	4, 6, 8	(100, 150, 200)	300	(2070)	Flange x Flange	a, b, c, f
AV-1	2 1/2, 4, 6, 8	(65, 100, 150, 200, 165)	300	(2070)	Flange x Flange	a, c, d, e, f
AV-1	2 1/2, 4, 6, 8	(65, 100, 150, 200, 76.1, 165)	300	(2070)	Flange x Groove	a, b, c, f
AV-1	2 1/2, 4, 6, 8	(65, 100, 150, 200, 165)	300	(2070)	Flange x Groove	a, c, d, e, f
AV-1	2 1/2, 4, 6, 8	(65, 100, 150, 200, 76.1, 165)	300	(2070)	Groove x Groove	a, c, f
AV-1	2 1/2, 4, 6, 8	(65, 100, 150, 200, 165)	300	(2070)	Groove x Groove	a, c, d, f

Remarks:

a. FM Approved for use with Model RC-1 retard chamber.

b. Available with Rp2 drain and ANSI, ISO, AS, or JIS flanges. Valves with Rp2 drain limited to vertical risers. Alarm test trim (Grinnell PSN 52-201-2-2002) must be according to installation requirements.

c. 300 psi (2070 kPa) rated valves are supplied with ductile iron bodies and covers.

d. Approved for use with European trim for European installations.

NOTE: The placement of a test and drain valve in lieu of the 2 inch (50 mm) NPS drain valve does not replace the need for an inspector's test connection at the most remote location of the sprinkler system.

The test and drain valve shall not be used in lieu of the inspector's test connection for testing of the entire wet piping system.

The test and drain valve shall only be used to exercise the clapper and check the mechanical alarm (water motor gong).

e. Approved when supplied with ANSI, ISO, AS, or JIS flanges.

f. Optional supervisory switch, P/N CEDPV, is available.

Company Name:	Tyco Fire Products LP
Company Address:	1467 Elmwood Ave, Cranston, Rhode Island 02910, USA
Company Website:	http://tyco-fire.com
New/Updated Product Listing:	No
Listing Country:	United States of America
Certification Type:	FM Approved
Class of Work:	1041-Alarm Check Valves

VPLX.EX6872 - Valves, Alarm

Valves, Alarm

[See General Information for Valves, Alarm](#)

TYCO FIRE & BUILDING PRODUCTS

EX6872

1400 PENNBROOK PKWY
LANSDALE, PA 19446-3840 USA

Alarm valves, Model AV-1-175 in the sizes 2-1/2, 4, 6, 8 in. for horizontal or vertical installation with the following end connections: flanged-flanged, flanged-grooved and grooved-grooved and for rated pressures not exceeding 175 psig.

Model AV-1-300 in the sizes 2-1/2, 4, 6, 8 in. for horizontal or vertical installation with the following end connections: flanged-flanged, flanged-grooved and grooved-grooved and for rated pressures not exceeding 300 psig.

Model RC-1 retarding chamber, Model WM-1 "Y" strainer, Model WMA-1, water motor and gong all for rated pressures not exceeding 300 psig.

Models AV-1-175, AV-1-300 valves may be provided with flanged connections drilled per ANSI, AS, ISO, and JIS specifications.

Trademark and/or Tradename: "CSC"

Last Updated on 2015-11-21

The appearance of a company's name or product in this database does not in itself assure that products so identified have been manufactured under UL's Follow-Up Service. Only those products bearing the UL Mark should be considered to be Certified and covered under UL's Follow-Up Service. Always look for the Mark on the product.

UL permits the reproduction of the material contained in the Online Certification Directory subject to the following conditions: 1. The Guide Information, Assemblies, Constructions, Designs, Systems, and/or Certifications (files) must be presented in their entirety and in a non-misleading manner, without any manipulation of the data (or drawings). 2. The statement "Reprinted from the Online Certifications Directory with permission from UL" must appear adjacent to the extracted material. In addition, the reprinted material must include a copyright notice in the following format: "© 2020 UL LLC"